

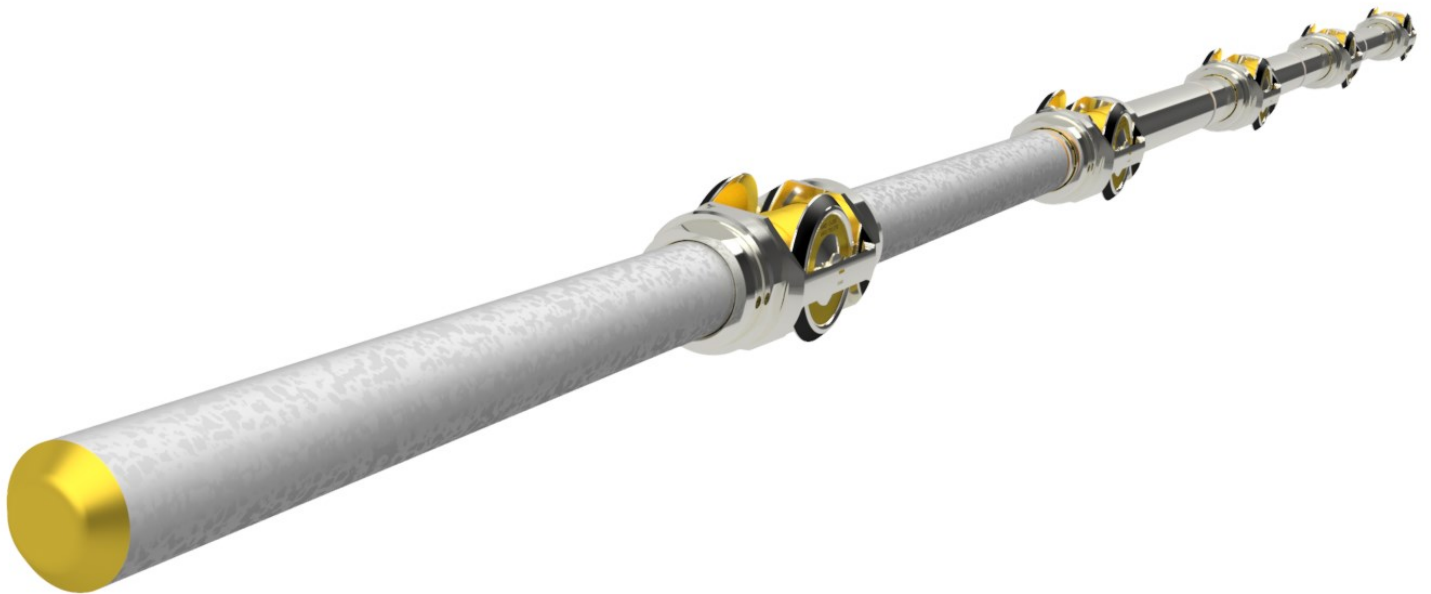

GARD U-line



WR5S

OPENHOLE





Technical Information Sheet

Technical Specification		
WR5S – Open Hole		
Wheel Camber Angle	0°	8°
Weight	18.6 kg (41.01 lbs)	
Length	366 mm (1.2 ft)	
Min Hole Size	8.0"	
Max Hole Size	12-1/4"	
Drag Coefficient Static	3	3.1
Drag Coefficient dynamic	2.8	2.9
Temperature rating	343° C (650° F)	
Pressure rating	30,000 psi	
Wheel Effective Diameter RANGE	7-1/4", 7-1/2" & 7-3/4"	
Chassis OD	6-3/4"	
WR5S Bore ¹	3-3/8" & 3-5/8"	
Standoff in 8.0" wellbore ²	31 mm	30 mm
Clear Low Side Angle of Bore Hole	64°	78°
Note 1	3-7/8" Standard Bore with sleeve options to accommodate 3-3/8" & 3-5/8" Logging Toolstrings	
Note 2	Standoff drops slightly when camber setting is applied on the wheels for 8" borehole ID (8-1/2" drill bit)	

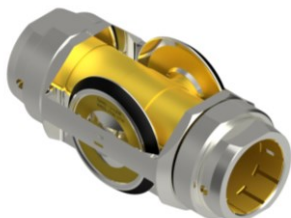
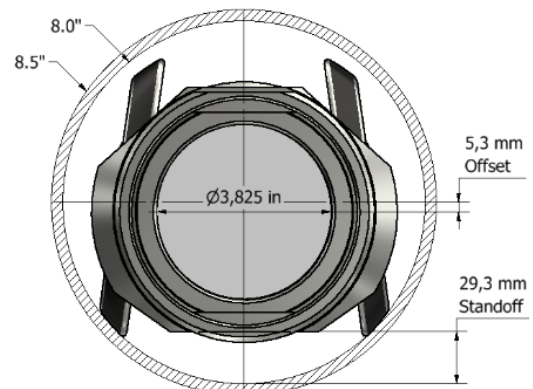
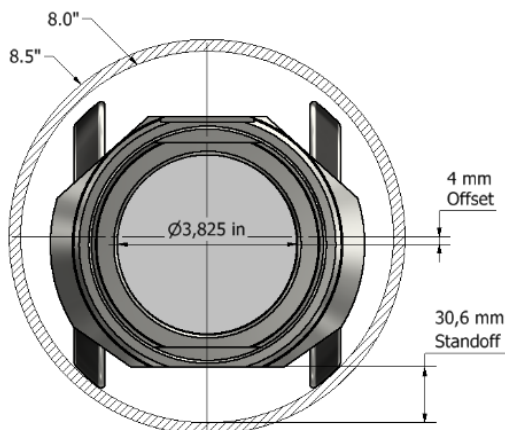



PERFORMANCE

GARD *U-line* conveyance systems enable the conveyance of wireline operations in challenging wellbores usually logged by heavy conveyance methods such as pipeconveyed logging, wireline tractors and LWD. GARD *U-line* technology is proven for conveying toolstrings in very challenging well profiles with high deviations up to 86° and at depths up to 20,000 ft.

SAFE SAMPLING

To minimise the risk when pulling out of the well, it is important to avoid running the tool on the low side of the borehole which accumulates most solids and more likely to go over a ledge or a washout. Due to consistent washouts and ledges, it is important to run the wheels which convey the toolstring away from these areas; a problem it has never been addressed fully in the industry. GARD *U-line* **Camber** wheel design was introduced to reduce tool drag significantly and avoid differential sticking.



DENSITY DOWN LOG

FLUID SAMPLING

SIDE CORING

360° ORIENTATION

GARD *U-line* technology, features a 360° swivel orientation setting for the logging tool sensors and samplers, allowing to set the logging tool at any custom angle required. This unique feature is maximising data quality and **eliminates failure risk** in logging inaccurate data.





NO DIFFERENTIAL STICKING

GARD *U-line* conveyance system reduces differential sticking due to four main technology advantages:

1. **SWIVEL** - Roller chassis can be set to self-orientate and swivel independently
2. **NO SCREWS** - Roller can be installed at optimum positions along the toolstring's length, using collets to secure it and spread equally the load on all the rollers
3. **LOW Rolling Friction Coefficient** - (3 - 6 %) on wheels
 - a. Reduce POOH cable tension by 40%
 - b. Create over 1" standoff to prevent differential sticking
4. **CAMBER WHEEL** - Camber angle (8°) on wheels to:
 - a. Minimise tear & damage on the mud cake when pulling
 - b. Prevent rapid wheel **embedment** in the mud cake when stationary

HPHT ENVIRONMENT

GARD *U-line* conveyance roller system is designed to operate at very extreme temperatures up to **650° Fahrenheit**. The wheel bearing design is:

1. Constructed with **HT** rated materials, (no nitrile and viton elastomers)
2. Validated for sand control, operating in drilling mud
3. Drilling mud self-lubricated, operating up to **30,000 psi**



Geothermal wells - This open hole roller design is compatible for HPHT wells.

HT collects for securing it to the toolstring instead of grub screws which can get loose at **HT**.

CENTRALISATION

A very simple and unique centralisation system, with an **offset of just 4-5 mm** for an 8" borehole. Eliminates stick-slip as there is no requirement for special equipment to achieve centralisation, such as conventional centralisers,. Centralisation can be achieved in any of the following roller settings illustrated on the table below:

Swivel	Wheel Camber	Offset
FREE	YES	5.3mm
FREE	NO	4mm
LOCKED	YES	5.3mm
LOCKED	NO	4mm

